



Ministry of Education, Youth Affairs & Sports

P O Box 103
Government Headquarters
Brades
Montserrat

Tel: 664-491-2541/2542

Fax: 664-491-6941

Email: education@gov.ms

Ref: MEYA&S/E/C/117

2nd February 2018

Dear Sir/Madam

**Re: TENDER FOR THE CONSTRUCTION AND SUPPLY OF WORK DESKS FOR
TEACHERS AT THE MONTSERRAT SECONDARY SCHOOL**

You are invited to submit a Tender for the above named project. Tender documents can be accessed by visiting the website below;

Hard copies can be downloaded from the Government of Montserrat website at
<http://www.gov.ms/tenders/>

The tender dossier consists of the following documents;

1. Instruction to Tenderers
2. Invitation to Tender
3. Evaluation Criteria
4. Undertaking Representations and Statements
5. Cost Breakdown
6. Form of Tender
7. General Conditions of Contract
8. Anti-Collusion Statement
9. Document checklist

Given the nature and urgency of the project, the supplier will be expected to supply the furniture in as little time as possible. Therefore, delivery time will be an important component in the tender evaluation process.

Please read Instructions to Tenderers before completing and submitting tenders, failure to do so may result in tenders being deemed non-compliant and rejected.

Any queries clarifications relating to the tender should be made to; Glenn Francis via email at Francisg@gov.ms no later than 12.00pm on 19th February 2018.

Tenders are to be received no later than 12:00 p.m. on 26th February 2018.

Yours sincerely



.....
Glenn Francis B.Ed., M.Sc.
Director of Education

Instructions to Tenderers

Submitting a Tender

- **Hard copies can be submitted by hand – Please follow the instructions set out below;**

Submitting a hard copy of your tender

You will need two plain envelopes for the Tender submission
You must follow these instructions, failure to do so may result in the bid being non-compliant and not considered any further.

Envelope 1.

Follow the steps written below:

1. Write the name of the bidder (Tenderer, Supplier) on this envelope
2. Write the name of the project and the address on the envelope as written below;

Supplier Name (insert company name)

Project Name

**TENDER FOR THE CONSTRUCTION AND SUPPLY OF WORK DESKS FOR
TEACHERS AT THE MONTSERRAT SECONDARY SCHOOL**

Departmental Tenders Committee

Ministry of Education Youth Affairs and Sports,

E. Karney Building

Little Bay, MSR1110, Montserrat.

3. Now put this envelope into another plain envelope (Envelope 2.)

Envelope 2 📁

Continue following the steps below:

4. Envelope 1 should now be inside this envelope (Envelope 2), seal the envelope and then write the Project Title and address for Tender return as written below

**TENDER FOR THE CONSTRUCTION AND SUPPLY OF WORK DESKS FOR
TEACHERS AT THE MONTSERRAT SECONDARY SCHOOL**
Departmental Tenders Committee
Ministry of Education Youth Affairs and Sports,
E. Karney Building, Little Bay, MSR1110, Montserrat.

***NB: Envelope 2 must not have the Bidders name on it or any other markings.**

Tenders are to be delivered to the address above tenderers will be given a receipt:

Tax

Except in cases where there is an exemption from tax, of which proof must be provided; residents of Montserrat for tax purposes are subject to tax on the profits from this project while non-residents are liable to a 20% Withholding Tax deduction from the gross amount.

Please take into consideration your tax obligations and liabilities to the Government of Montserrat. For further information please contact Montserrat Customs & Revenue Service (MCRS) via email at irev@gov.ms

This tender is based on the Form of Tender, Conditions of contract, Tax Compliance Certificate and Anti-Collusion Statement, Cost Breakdown and Program of works statement herein after referred to as the Contract Documents.

Obligations

- (1) The contract conditions adopted for this project will be the Government of Montserrat General Conditions of Contract which is included in this dossier;
- (2) Tenderers must fully complete and submit the Form of Tender. Failure to fully complete and return this critical document and provide the additional information stated in these instructions will render the bid non-compliant and it will be rejected.

(3) Tenderers must sign and submit the **DESCRIPTION AND SCOPE OF WORKS** document and supply all documentation as indicated on the tender checklist.

(4) Tenderers must submit a current Tax Compliance Certificate with their bid if their place of business is registered in Montserrat.

(5) **Tax**

Except in cases where there is an exemption from tax, of which proof must be provided; residents of Montserrat for tax purposes are subject to tax on the profits from this project while non-residents are liable to a 20% Withholding Tax deduction from the gross amount.

Please take into consideration your tax obligations and liabilities to the Government of Montserrat. For further information please contact Montserrat Customs & Revenue Service (MCRS) via email at irev@gov.ms

(6) All tenders will be arithmetically checked, any errors will be brought to the tenderers attention. The rates supplied would be the basis for the arithmetic correction and would be the determining factor for any queries about the corrected price. A tenderer whose tender sum is subject to arithmetical correction will be informed and asked whether he accepts the corrected tender sum. Failure to accept the corrected sum will result in the rejection of the tender.

(7) Any bid received after the deadline for submission of bids prescribed in (5) above will be rejected.

(8) Tenderers are not allowed to submit multiple or alternative tenders.

(9) The **Departmental Tenders Committee** is not bound to accept the lowest or any tenders and has the right to accept or reject any tender offers.

(10) Tenderers must complete the Form of Tender and return this with their tender submission. The currency for completing the Form of Tender is Eastern Caribbean Dollar. Tenders in other currencies will be rejected.

INVITATION to TENDER

BACKGROUND

Most of the furniture at MSS needs to be replaced. Much of this furniture was procured in 1995, prior to the start of the volcano eruption, and in some instances was repatriated from Plymouth. Most are in a state of disrepair due to wear and termite infestation. The schools were forced to dispose of a portion of its stock of desks and chairs because of the advanced state of their deterioration. The school is not currently able to provide suitable and safe furniture for all of the students.

The desks and chairs requested will serve to support the child-centered learning being established at the school through the facilitation of group work, exploration and role play with minimum loss of time for classroom rearrangement.

Objective

To provide the basic furniture necessary to outfit MSS which currently has inadequate furniture for the 2017/2018 academic year. This in line with the objective of the Education Development Plan one of whose aim is to create *“A modern, enriching, child-centred learning community, with a nurturing teaching and learning environment, created to respond to the changing and diverse school population”*, but also in line with the requirements of the Montserrat Labour Code which requires employers to *“provide and maintain suitable facilities for employees to sit during the course of their employment”* and to *“ensure, as far as is reasonably practicable, that no unsafe structure exists in the workplace that is likely to expose persons to risks to bodily injury”*.

The Ministry has been allocated funds towards the supply of the following:

- Student desks
- Student chairs
- Teachers' chairs
- ICT chairs
- Teachers Desks

This tender is for the construction and supply of twelve (12) teachers work desks only as per the design which is included in this tender dossier.

SCOPE OF WORKS

The desk must be constructed according to the included drawings. Best practices workmanship and materials are expected in all items and at every stage of the construction process. The Ministry reserves the right to refuse payment on any or all of the items supplied if it is dissatisfied with any of the products and if a suitable and practical remedy cannot be found.

All wooden components must be treated against termites and against wood worm.

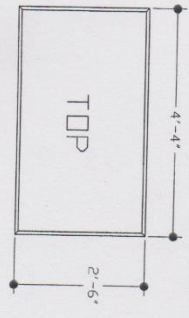

PLAN VIEW

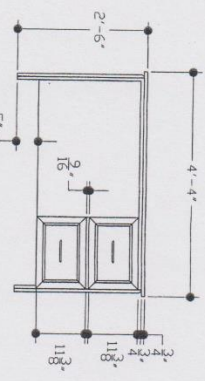

FRONT VIEW

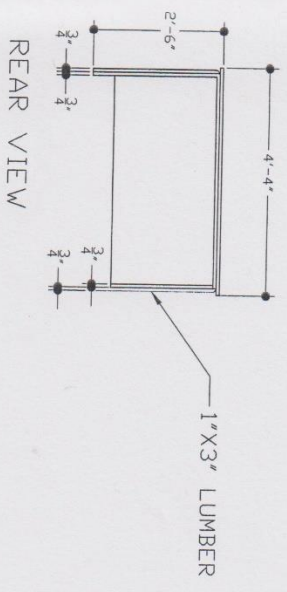

REAR VIEW

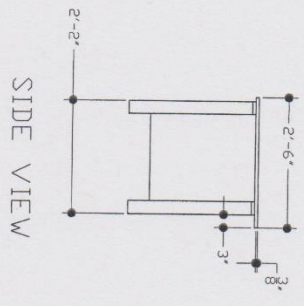

SIDE VIEW

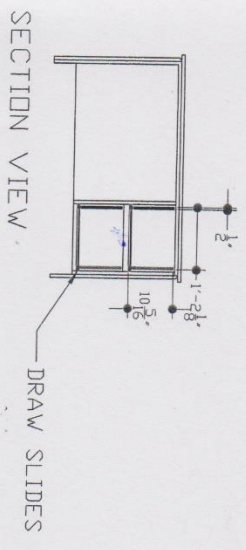

SECTION VIEW

MSS TEACHER DESK

NOTE

TEACHER DESK: TOP AND SIDES WILL BE BUILT FROM RED CEDAR REAR/BACK WILL BE 1/2" FINISHED PLY WOOD FINISH WITH 2 COATS OF VARNISH DRAWS FRONT WILL BE RAISED SIDE SWILL BE MADE FROM 3/4" FINISHED PLYWOOD DRAW BOTTOM WILL BE 1/4" FINISHED PLYWOOD 1" X 3" WILL BE RED CEDAR ALL JOINTS WILL BE FIXED WITH NAIL AND GLUE

EVALUATION OF TENDERS

All tenders will be evaluated based on the criteria below and the highest score will be recommended for contract award.

The evaluation will assume a two-stage process:

Administrative compliance:

At this stage bids will be checked to ascertain the following:

- Was the bid received before the deadline?
- Was the bid packaged as instructed in the 'invitation to tender' and the 'instructions to tender'?
- Were all of the required documents completed and signed as required?
- Were all of the mandatory documents on the check list provided with the bid?

If the response to any of the questions above is negative the bid will be rendered non-compliant and the bid will not be considered for further evaluation.

Technical compliance (100%)

The technical compliance consideration will be based on the extent to which the furniture meets the needs of the school as described in this tender issue. The consideration will be as follows:

Quality Assurance (20%)

The Bidder is expected under this criteria to indicate what quality assurance measures are in place at their establishment to ensure that finished products are of the highest quality highest strength and highest durability.

The bidder which has the best and most credible focus on product quality will be assigned a score out of a maximum of 20 points and all other bidders shall be scored on this criteria accordingly.

Experience (20%)

The Bidder will be required to indicate their experience in doing work of this nature and of this volume within a limited time frame. It would be advantageous to the bidder if he can cite works of this nature which was successfully completed within the last 4 years. Other evidence of experience may be presented such as testimonials of satisfied clients and or photographs of similar works.

The bidder with the most relevant experience will be assigned a score on this criteria and all other bidders shall be scored accordingly

Cost (45%)

Cost is the most important criteria but issues related to product quality will also be considered as GoM seeks to get maximum value for money. Hence the least cost may not necessarily win this tender.

The bidder with the lowest cost will be assigned a score on this criteria and all other bidders shall be scored accordingly.

Any Warranty (10%)

Under this criteria the bidder is expected to propose a warranty period on workmanship. This is to ensure government gets work of a high quality.

The bidder which offers the longest warranty period will be assigned a score and all others will be scored accordingly.

Delivery time (5%)

The school is quite anxious to receive the desks in the shortest possible time without any loss of quality. Hence it places no time limit on delivery. Notwithstanding the bidder with the shortest delivery time will receive a score and all others will be scored accordingly on this criteria.

UNDERTAKINGS REPRESENTATIONS AND STATEMENTS

Please make a statement to indicate quality assurance measures

Please make a statement to indicate the experience of the bidder

Please make a statement to indicate any warranties which are offered

Name of Bidder

Signed

COST BREAKDOWN

ITEM	QUANTITY	UNIT COST	TOTAL COST
1/2" FINISHED PLYWOOD			
1/4" FINISHED PLYWOOD			
RED CEDAR			
VARNISH			
FITTINGS			
TOTAL MATERIAL COST			
TOTAL LABOR COST			
TOTAL TRUCKING COST			

Name of Bidder _____

Signed _____

FORM OF TENDER

**Departmental Tenders Committee
Ministry of Education Youth Affairs and Sports,
E. Karney Building
Little Bay, MSR1110, Montserrat.**

Dear Sir/Madam;

**Re: TENDER FOR THE CONSTRUCTION AND SUPPLY OF WORK DESKS FOR
TEACHERS AT THE MONTSERRAT SECONDARY SCHOOL”**

I/We the undersigned undertake supply the furniture described herein in accordance with the Contract Agreement, and as described in the captioned project outlined above as provided in the tender documents for the sum of:

EC\$..... being
the total cost for supplying all of the work desks described herein..

If my/our tender is accepted, I/We undertake to deliver the furniture within a period ofweeks.

I/We understand I/We shall not be reimbursed for any cost that may have been incurred in compiling this tender. I/We confirm this tender shall remain valid for a period of 90 days from the date of submission of this tender.

Except in cases where there is an exemption from tax, of which proof must be provided; residents of Montserrat for tax purposes are subject to tax on the profits from this project while non-residents are liable to a 20% Withholding Tax deduction from the gross amount.

Please take into consideration your tax obligations and liabilities to the Government of Montserrat. For further information please contact Montserrat Customs & Revenue Service (MCRS) via email at irev@gov.ms

Name.....
Signed.....
Name of firm (If Applicable)
Address.....
.....
Tel. nr.....
Fax nr.....
Email Address
Date.....

GOVERNMENT OF MONTSERRAT (GOM)

**GENERAL CONTRACT CONDITIONS FOR THE SUPPLY OF FURNITURE TO THE
MONTSERRAT SECONDARY SCHOOL**

This Agreement is made the..... day of..... **2018** between the **GOVERNMENT OF MONTSERRAT** having its headquarters at Government Headquarters, Brades, Montserrat acting herein and represented by the Permanent Secretary, Ministry of Education, Youth Affairs and Sports (hereinafter referred to as "**GOM**") of the one part and (*supplier's company*) whose address is Acting herein and represented by (*name of representative*) (Hereinafter referred to as "**the Supplier**") of the other part.

1. INTERPRETATION

1.1. In these conditions:-

The Contract means the agreement concluded between the **GOM** and the Supplier/Service Provider including all specifications and Terms of Reference; and in which, inter alia, the tender instructions, scope of works along with the outcomes, deliverables and considerations are clearly stipulated, and other documents which may be incorporated or referred to herein;

The Contracting authority means the Ministry of Education of the Government of Montserrat.

The Service Provider means the company/ companies/ individual that is responsible for carrying out the requirements of the contract, that is, the preparation, delivery and service of meals under the schools lunch program.

The Administrator or CA means the duly authorized representative of **GOM** for the administration of this Agreement who has care and control of this Contract and whose name will be provided to the Service Provider. The Administrator shall have final authority for acceptance of the **Service Providers** performance, and if

satisfactory, shall initiate the process for approval of payment to the **Service Provider**. No payment shall be made without such approval.

The Contract Price means the price per meal to be paid by **GOM** and the method of payment of the Contract Price shall be agreed between the parties.

The Specification means the GOM's requirements for the supply of furniture for the Montserrat Secondary School as described earlier in this document.

2. VARIATIONS OF CONDITIONS

The contract shall be carried out in accordance with these Conditions and requirements and no amendment or variation either to the terms and conditions or to the requirements shall be made unless agreed in writing between the parties and incorporated into this agreement.

3 NON-DELIVERY

Without prejudice to any other right or remedy, should the Service Provider not deliver the Services or any portion thereof within the time or times specified in the Contract, except in cases of force majeure and subject always to the receipt of written notice within 5 days of the force majeure event relied on, or if the Services are delayed due to events outside of the Supplier's control, in which case the Supplier shall be entitled to a fair and reasonable time for such delay, then:

- 3.1 The **GOM** shall be at liberty to determine the Contract and to procure services of the same or similar description from another Supplier to make good such default; and,
- 3.2 The **GOM** shall recover from the Supplier any sum or sums paid to the Supplier in respect of the services. Also, the **GOM** shall be able to recover from the supplier any increased costs resulting from obtaining supplies from an alternative supplier.

4 PAYMENT

- 4.1 As full consideration for the Services performed by the Service Provider under the terms of this Contract, the **GOM** will pay the fees as outlined within 10 days of receipt of an invoice, payable against original invoices delivered to the **GOM** by the Supplier, provided that **GOM** give notice in writing of its intention not to pay such fee and provide the relevant reason where:
 - a. The Service Provider has failed to carry out services, or has inadequately carried out services required by this Contract to be carried out and has not remedied such failure or deficiency within a reasonable time;
 - b. The Service provider, by act or omission has caused damage to personnel or property of the **GOM** or any third party;
 - c. There is a breach of any other provision of this Contract; and upon giving such notice the **GOM** may withhold payment accordingly.

- 4.2 **GOM**, whenever under the Contract any sum of money shall be recoverable from or payable by the Service Provider, the same may be deducted from any sum then due or which at any time thereafter may become due to the Service Provider under the Contract as a debt, providing that such sum is agreed by the parties as recoverable by GOM or has been fully ascertained and substantiated.
- 4.3 If any fee or portion thereof payable under this Agreement shall be unpaid 20 working days after receipt of an original invoice in respect of such fee the Service Provider may give notice to the **GOM** requiring the **GOM** to pay such fee or part thereof and if the **GOM** shall fail to comply with such notice, the Service Provider may terminate or suspend this Contract immediately. Nothing stated in this provision shall operate to impair the right of the Service provider to recover any such fee in any other manner.
- 4.4 Any payment made after the due date for payment shall attract interest at a rate of 2 per centum

5 INDEMNITY AND INSURANCE

- 5.1 Subject to clause 5.2 and without prejudice to its liability for breach of any of its obligations under the Contract, the Service Provider shall be liable for and shall indemnify the **GOM** against any liability, loss, costs, expenses, claims or proceedings whatsoever arising under any statute or common law in respect of:-
- 5.1.1 Any loss of or damage to property (whether real or personal) caused by the Service Provider, its servants or agents; and
- 5.1.2 Any injury to any person including injury resulting in death, in consequence of or in any way arising out of any negligent act or omission which may arise in the performance of the Contract by or on behalf of the Service Provider except insofar as such loss, damage or injury shall have been caused by negligence on the part of the **GOM**, its employees, servants or agents.
- 5.3 Neither party shall be liable to the other for any indirect ,special or consequential loss (including but not limited to loss of profit whether direct or indirect ,loss of production, loss of contracts, loss of use, loss of business, and loss of business opportunity.
- 5.4 Further, and without prejudice to the aforesaid limit of liability and such liability of the service provider for the loss or damage in respect of any claim or claims shall be limited to such sum or sums as it would be just and equitable for the service provider to pay having regard to the service provider's responsibility for the same and on the basis that:
- a) all other parties appointed or to be appointed by the GoM to perform related services in connection with the Contract shall be deemed to have provided undertakings on terms no less onerous than this Contract and shall be deemed to have paid to the GoM such contribution as it would be just and equitable for them to pay having regard to their responsibility for the loss or damage; and

- b) it shall be deemed that all such other parties have not limited or excluded their liability to the GoM for the loss or damage in any way which may be prejudicial to the Service Provider's liability under this clause

6. INSURANCE

- 6.1 The Service Provider shall insure against its full liability under this Contract.
- 6.2 The Service Provider shall produce to **GOM**, upon request, documentary evidence that insurance is properly maintained.

7 ASSIGNMENT

- 7.1 The **GOM** shall be entitled to assign the benefit of this Contract or any part thereof and shall give written notice of any assignment to the Service provider.
- 7.2 The Service Provider shall not:-
 - 7.2.1 Assign the Contract or any part thereof or the benefit or interest of the Contract without the prior written consent of the **GOM**; or
 - 7.2.2 Subcontract any provision of the Contract or any part thereof to any person without the previous written consent of the **GOM**, **such consent shall not be unreasonably withheld or delayed**, which if given shall not relieve the Service Provider from any liability or obligation under the Contract and the Service Provider shall be responsible for the acts, defaults, or neglect of any sub-service supplier or his agents or employees in all respects as if it were the acts, defaults or neglect of the Service Provider or its agents or employees.

8 CONFIDENTIALITY

- 8.1 All information, requirements, documents and other data which the **GOM** may have imparted and may from time to time impart to the Service Provider relating to its business, employees, customers, prices, requirements, or any computer system (including hardware and software or maintenance thereof) and including any technical specifications is proprietary and confidential. The Service Provider shall not at any time during or after the term of this Contract divulge or allow to be divulged to any person any information which comes into its possession by virtue of its performance of this Contract, which relates to the business and affairs of the **GOM** except upon authorization by the **GOM**. The Service Provider shall not seek to acquire any such information outside of the performance of its duties under this Contract.
- 8.2 The Service Provider hereby agrees that it shall use such confidential information and all other data solely for the purposes of this Contract and that it shall not at any time during or any time after the completion, expiry or termination of this Contract, disclose the same whether directly or indirectly to any third party without the **GOM's** prior written consent.
- 8.3 The obligations set forth in Clauses 8 and 16 shall expire two (2) years after the termination of the Contract.

9 BRIBERY AND CORRUPTION

Either party shall be entitled to determine the Contract and to recover from the other party the amount of any loss resulting from such action if:-

- 9.1 Any party has offered or given or agreed to give to any person any gift or consideration of any kind as inducement or reward for doing or forbearing to do or for having done or forborne to do any action in relation to the Contract or any other contract with the other party; or
- 9.2 The like acts shall have been done by any person employed by the Parties or acting on its behalf (whether with or without the knowledge of the Party); or
- 9.3 In relation to any contract with the **GOM** the Service Provider or person employed by it or acting on its behalf shall:-
 - 9.3.1 Have committed an offence under the Integrity in Public Office Act No. 2 of 2010 or
 - 9.3.2 Have given any fee or reward, the receipt of which is an offence, under the relevant laws.
- 9.4 In the performance of their obligations under or in connection with this Contract, the parties, their agents and employees shall comply with all applicable laws, rules and regulations including and not limited to the Bribery Act 2010 and where appropriate, the OECD Convention on Combating Bribery of Foreign Public Officials in International Business Transactions.

10 TERMINATION

- 10.1 The **GOM** may terminate this Contract in any of the circumstances set out in 10.2 below by giving to the Service Provider notice in writing where the Service Provider:-
 - 10.1.1 commits a material breach of any of its obligations under this Contract; and despite notice of such breach in writing by the GoM to the Service provider, the Service Provider fails to remedy such breach within 14 days of the notice then the GoM may terminate the Contract forthwith.
 - 10.1.2 becomes bankrupt or makes a composition or arrangement with its creditors or has a proposal in respect of its company or partnership for the voluntary arrangement for the composition of debts or scheme or arrangement approved in accordance with the Companies Act or the Bankruptcy Act;
 - 10.1.3 Has a winding-up order made or (except for the purposes of amalgamation or Reconstruction) a resolution for voluntary winding-up passed;

- 10.1.4 has a provisional liquidator, receiver or manager of its business or undertaking duly appointed;
- 10.1.5 has an administrative receiver appointed;
- 10.1.6 has possession taken by or on behalf of the holders of any debentures secured by a floating charge of any property comprised in or subject to the floating greater than US\$25,000.00
- 10.1.7 Is in circumstances which entitle a court or creditor to appoint or have appointed a receiver, a manager or administrative receiver or which entitle a court to make a winding-up order; then in any such circumstances the **GOM** may without prejudice to any accrued rights or remedies under this Contract, terminate the Contract by giving notice in writing.
- 10.2 If the Contract is terminated as provided in this condition then the **GOM** shall:-
- 10.2.1 Cease to be under any obligation to make further payment until the costs or loss resulting from or arising out of the termination of this Contract shall have been calculated, and shall make such payment only in accordance with a court order or pursuant to the applicable law;
- 10.2.2 Be entitled to repossess any of its Equipment (if any) in the possession of the Service Provider;
- 10.2.3 Be entitled to deduct any losses to the **GOM** resulting from or arising out of the termination of this Contract (from any sum or sums which would but for the termination of the contract as aforesaid have been due from the **GOM** to the Service Provider as a debt). Such loss shall include the reasonable cost to the **GOM** of the time spent by the **GOM** in terminating of the Contract as aforesaid have been due to the Service Provider.

11. WAIVER

- 11.1 The failure by either party to enforce at any time or for any period any one or more of the terms or conditions of this Contract shall not be a waiver of them or of the right at any time subsequently to enforce all terms and conditions of this Contract. No waiver of any default or non-performance by any party shall be considered a waiver of any subsequent default or non-performance.

12. COMPLETE CONTRACT

- 12.1 This Agreement supersedes any prior Agreement between the parties whether written or oral relating to the subject matter hereof, but without prejudice to any rights which have already accrued to either of the parties. This Agreement shall be governed by the laws of Montserrat in every particular and shall be deemed to be made in Montserrat.

13. GOVERNING LAW

13.1 This Contract shall be governed by the laws of Montserrat in every particular and shall be deemed to be made in Montserrat.

14. FORCE MAJEURE

Both parties shall be released from their respective obligations in the event of national emergency, natural disaster, war, prohibitive governmental regulation or if any other cause beyond the reasonable control of the parties or either of them renders the performance of this Contract impossible whereupon all money due under this Contract shall be paid immediately.

15. NOTICES

15.1 Any notice required to be served under this Agreement shall be in writing and may be served by electronic mail to the correct address, facsimile transmission to the correct number, post or hand delivery to the last known business address of the party upon whom it is being served. Notice shall be deemed to have been effected within 24 hours of the date of sending of the notice when sent by electronic mail or facsimile transmission, within 72 hours of the date of posting of the notice when sent by post and upon delivery when hand delivered.

A notice shall be delivered as follows:

if to the Service Provider, to:

Name _____
Designation _____
Address _____
Tel: No _____
Fax _____
Email _____

A. if to the GOM, to:

Name: Glenn Francis
Director of Education
The Ministry of Education Youth Affairs and Sports
E. Karney Osborne Building
Little Bay
Montserrat
Tel: (664) 491-2541/2
Email: education@gov.ms

16. MEDIATION AND ARBITRATION

If a dispute arises under this Contract, the parties agree that they would first exhaust the provisions outlined in sections 46, 47 and 48 of the Public Finance (Management and Accountability) Procurement regulations 2012. If the parties fail to come to an

amicable resolution through the provisions outlined above, then the dispute shall be settled with the help of a mutually agreed-upon mediator in Montserrat. The parties shall share any costs and fees other than attorney fees associated with the mediation equally.

17. SIGNATURES

17.1 Each party represents and warrants that on this date they are duly authorized to bind their respective principals by their signatures below.

IN WITNESS WHEREOF, the parties have executed this Contract on the dates set forth first above, with full knowledge of its content and significance and intending to be legally bound by terms hereof.

Insert names etc.

A. SERVICE PROVIDER

Name.....

Designation.....

Signature.....

Witness Name.....

Designation.....

Signature.....

B. GOM

Name: Mrs Mary Lynch

Designation: Accounting Officer , Ministry of Education

Signature.....

Witness Name.....

Designation.....

Signature.....

GOVERNMENT OF MONTSERRAT

TENDER SUBMISSION ANTI-COLLUSION CERTIFICATE

I/WE CERTIFY THAT THIS TENDER IS MADE IN GOOD FAITH, AND THAT WE HAVE NOT FIXED OR ADJUSTED THE AMOUNT OF THE TENDER BY OR UNDER OR IN ACCORDANCE WITH ANY AGREEMENT OR ARRANGEMENT WITH ANY OTHER PERSON. I/WE ALSO CERTIFY THAT WE HAVE NOT AND I/WE UNDERTAKE THAT WE WILL NOT BEFORE THE AWARD OF ANY CONTRACT FOR THE WORK:

DISCLOSE THE TENDER PRICE OR ANY OTHER FIGURES OR OTHER INFORMATION IN CONNECTION WITH THE TENDER TO ANY OTHER PARTY (INCLUDING ANY OTHER COMPANY OR PART OF A COMPANY FORMING PART OF A GROUP OF COMPANIES OF WHICH I AM/WE ARE A PART OF) NOR TO ANY SUB-CONTRACTOR (WHETHER NOMINATED OR DOMESTIC) NOR SUPPLIER (WHETHER NOMINATED OR DOMESTIC) OR ANY OTHER PERSON TO WHOM SUCH DISCLOSURE COULD HAVE THE EFFECT OF PREVENTING OR RESTRICTING FULL COMPETITION IN THIS TENDERING EXERCISE.

ENTER INTO ANY AGREEMENT OR ARRANGEMENT WITH ANY PERSON THAT THEY SHALL REFRAIN FROM TENDERING, THAT THEY SHALL WITHDRAW ANY TENDER ONCE OFFERED OR VARY THE AMOUNT OF ANY TENDER TO BE SUBMITTED OR OTHERWISE COLLUDE WITH ANY PERSON WITH THE INTENT OF PREVENTING OR RESTRICTING FULL COMPETITION PAY, GIVE OR OFFER PAY OR GIVE ANY SUM OF MONEY OR OTHER VALUABLE CONSIDERATION DIRECTLY OR INDIRECTLY TO ANY PERSON FOR DOING OR HAVING DONE OR CAUSING OR HAVING CAUSED TO BE DONE IN RELATION TO ANOTHER TENDER OR

PROPOSED TENDER FOR THE WORK ANY ACT OR THING OF THE SORT DESCRIBED AT I), II) OR III) ABOVE.

I/WE FURTHER DECLARE THAT I/WE HAVE NO KNOWLEDGE EITHER OF ANY SUM QUOTED OR OF ANY OTHER PARTICULARS OF ANY OTHER TENDER FOR THIS CONTRACT BY ANY OTHER PARTY.

I/WE FURTHER CERTIFY THAT THE PRINCIPLES DESCRIBED ABOVE HAVE BEEN, OR WILL BE, BROUGHT TO THE ATTENTION OF ALL SUB-CONTRACTORS, SUPPLIERS AND ASSOCIATED COMPANIES PROVIDING SERVICES OR MATERIALS CONNECTED WITH THE TENDER AND ANY CONTRACT ENTERED INTO WITH SUCH SUB-CONTRACTORS, SUPPLIERS OR ASSOCIATED COMPANIES WILL BE MADE ON THE BASIS OF COMPLIANCE WITH THE ABOVE PRINCIPLES BY ALL PARTIES.

I/WE ACKNOWLEDGE THAT ANY BREACH OF THE FOREGOING PROVISIONS SHALL LEAD AUTOMATICALLY TO THIS TENDER BEING DISQUALIFIED AND MAY LEAD TO CRIMINAL OR CIVIL PROCEEDINGS. THE GOVERNMENT OF MONTSERRAT SHALL TREAT ANY TENDER RECEIVED IN CONFIDENCE BUT RESERVES THE RIGHT TO MAKE THE SAME AVAILABLE TO ANY OTHER FUNDING ORGANISATION OR STATUTORY REGULATORY AUTHORITY EITHER HAVING JURISDICTION OVER THE WORKS OR WHO MAY NOW OR AT ANY TIME IN THE FUTURE HAVE STATUTORY POWER TO REQUIRE DISCLOSURE OF THIS TENDER.

IN THIS CERTIFICATE, THE WORD 'PERSON' INCLUDES ANY PERSONS AND ANY BODY OR ASSOCIATION, INCORPORATED OR UNINCORPORATED; ANY AGREEMENT OR ARRANGEMENT INCLUDES ANY TRANSACTIONS, FORMAL OR INFORMAL AND WHETHER

LEGALLY BINDING OR NOT; AND 'THE WORK' MEANS THE WORK IN RELATION TO WHICH THIS TENDER IS MADE.

SIGNATURE..... IN CAPACITY OF
.....

DATE.....2018

DULY AUTHORISED TO SIGN TENDERS AND ACKNOWLEDGE THE CONTENTS OF THE ANTI-COLLUSION CERTIFICATE

FOR AND ON BEHALF OF:

NAME OF
FIRM.....

FULL POSTAL
ADDRESS.....

TELEPHONE NO..... FAX NO
.....

TENDER CHECKLIST

The following documents should be provided for a tenderer's bid to be valid. Bidders are asked to supply and tick off the following information. Failure to provide any of the stated documents may render the bid non-compliant.

1. Completed and signed Form of Tender. The form of tender document shall be signed by the person legally authorized to bind the firm to a Contract.
2. Tax/Social Security compliance certificate (if locally based)
3. Signed Anti-Collusion Statement
4. Undertakings representations and statements

5. General Conditions of Contract

6. Detailed drawings and sketches of furniture

7. Cost breakdown

.....
Signed by Tenderer